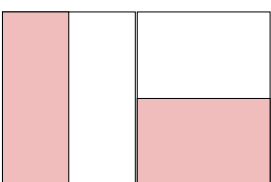
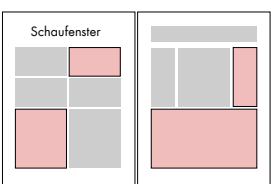

GUTE KÜCHE | SPECIAL EDITION

	Double spread	420 x 265 mm ¹	Inside front cover + page 3	19.600,-
			Page 4 + 5	25.500,-
			Design costs for advertorials³	23.550,-
				1.000,- ²
Surcharge for desired placement, 10 % of single-page rate.				

	Single page	210 x 265 mm ¹	Outside back cover	11.500,-
			1st righthand page, IFC or IBC	14.900,-
			2nd righthand page	13.150,-
			Design costs for advertorials³	12.600,-
			Surcharge for desired placement, 10 % of single-page rate.	500,- ²
			Surcharge cannot be reduced.	

	1/2 page	1/2 Seite portrait (105 x 265 mm)	7.450,-
		1/2 Seite landscape (210 x 132mm)	

	Schaufenster	1/1 page	incl. design costs	8.250,-
		1/2 page portrait		4.650,-
		1/2 page landscape		
		1/4 page portrait		2.650,-
		1/4 page landscape		
		1/8 page		1.550,-
		Designed as advertorial or as classic advertisement.		

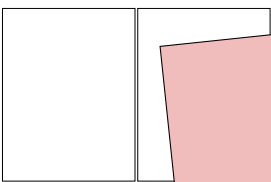
	Enclosure	Minimum format	115 x 140 mm	Total edition AT & DE up to 20 g	150,-
		Maximum format	200 x 255 mm	per additional 10 g	20,-
		The larger page must be enclosed.		Design costs by Red Bull Media House according to extent of work done.	

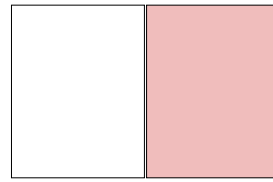
	Supplement	Minimum format	115 x 140 mm	Total edition AT & DE up to 20 g	150,-
		Maximum format	210 x 265 mm	per additional 10 g	20,-
		Head trim	+6 mm	Design costs by Red Bull Media House according to extent of work done.	
		Top edge, base, side, fold	+3 mm		
		Placement	curved		

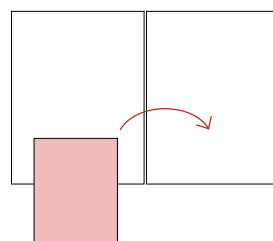
	Sachets ad space (from 1/1 page)	Minimum format	60 x 100 mm	Total edition AT & DE per 1.000	120,-
		Maximum strength	2 mm		
		Adhesive difference	±10 mm		
		Sachet shape	square or rectangular (others upon request)		
		Delivery	upright in cardboard box		
		Placement	curved		
		Manual gluing on request.			

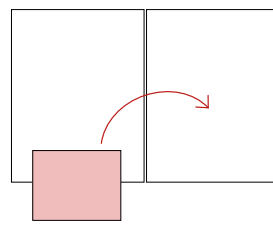
	TOC ad space (from 1/1 page)	Minimum format	60 x 80 mm	Total edition AT & DE per 1.000	120,-
		Maximum strength	210 x 265 mm		
		Adhesive difference	±10 mm		
		Delivery	cut-to-size		
		Placement	curved		
		Manual gluing on request.			

Advertorials: are charged at page price + design costs. Costs for photography are calculated according to complexity. Print material for advertorials, promotions etc. to be delivered 2 weeks before ad copy deadline (except for enclosures and supplements - timing as per agreement).

Postage costs: Subscription circulation incurs postage costs according to the current postal rate. Minimum circulation: 10,000 copies per country. Partial circulation: +20 %.

T&C: redbullmediahouse.com/agb-print

Data delivery: redbullmediahouse.com/datenanlieferung

All prices in euros excluding statutory taxes and duties. ¹Plus 3 mm bleed on all sides; motifs running over the gutter: 3 mm displacement in the core, allow 5 mm waistband allowance between U2/U3 and core. ²Not eligible for discount and AE. ³One-time feedback loop included.