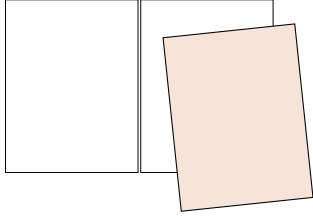
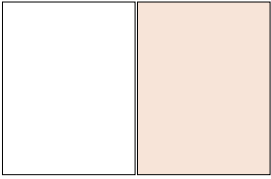

	Double spread	430 x 280 mm ¹		32.500,- 44.300,- 37.900,- 1.000,- ³
---	----------------------	---------------------------	--	--

Special submission U2 + page 3
Special submission page 4 + 5
Additional design costs for advertorials²

	Enclosure	Minimum format 105 x 148 mm Maximum format 185 x 250 mm The longer page must be enclosed.	Total edition weighing up to 20 g per additional 10 g	150,- 20,-
---	------------------	---	--	---------------

	Single page	215 x 280 mm ¹		19.800,- 25.400,- 22.600,- 21.500,- 500,- ³
---	--------------------	---------------------------	--	--

Special submission U4
Special submission 1st right-hand page, U2 or U3
Special submission 2nd right-hand page
Additional design costs for advertorials¹

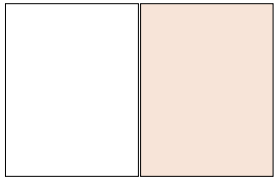
	Supplement	Minimum format 115 x 140 mm Maximum format 215 x 280 mm Top edge +15 mm base, side, fold +3 mm Placement curved	Total edition weighing up to 20 g per additional 10 g	150,- 20,-
---	-------------------	---	--	---------------

	1/2 page	107,5 x 280 mm (vertical) 215 x 140 mm (horizontal)		13.200,- 13.200,- 500,-
---	-----------------	--	--	-------------------------------

Additional design costs for advertorials¹

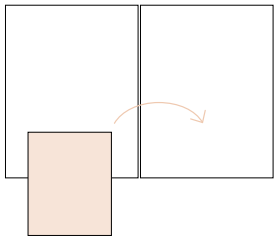
	Sachets ad space (from 1/1 page)	Minimum format 60 x 100 mm Maximum strength depending on shape & content Adhesive difference 5 to 10 mm Sachet shape square or rectangular (other upon request) Delivery upright in a box Placement curved Attachment by hand on request	Total edition up to 1.000	120,-
--	--	--	----------------------------------	-------

	1/3 Seite	73 x 280mm (vertical) 215 x 73mm (horizontal)		9.900,- 9.900,- 500,-
---	------------------	--	--	-----------------------------

Additional design costs for advertorials¹

	Inspiration	1/4 page 1/8 page Designed in the look & feel of carpe diem	incl. design costs	4.800,- 3.450,-
---	--------------------	---	--------------------	--------------------

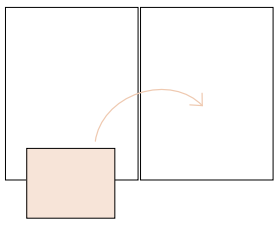
	TOC ad space (from 1/1 page)	Minimum format 60 x 100 mm Maximum format 125 x 240 mm Adhesive difference 5 to 10 mm Delivery cut-to-size Placement curved Attachment by hand on request	Total edition up to 1.000	120,-
---	--	--	----------------------------------	-------

	Tip (health, fashion)	1/4 page carpe diem look and feel		
---	------------------------------	--------------------------------------	--	--

Advertorials: are charged at page price + design costs. Costs for photography are calculated according to complexity. Print material for advertorials, promotions etc. to be delivered 2 weeks before ad copy deadline (except for enclosures and supplements - timing as per agreement).

Postage costs: Postage costs according to the current postal rate apply to the subscription edition. Partial circulation +20 % surcharge. All other special advertising formats on request.

Special submissions: Surcharge for other desired placement: 10 % of the single-page rate. Surcharges are not discountable.

AGB: redbullmediahouse.com/agb-print

Data delivery: redbullmediahouse.com/datenanlieferung

All prices in euros excluding statutory taxes and duties. ¹ Not eligible for discount and AE. ³ One-time feedback loop included.

KLASSISCH DISPLAY

	Leaderboard	728 x 90 px Desktop ROS TKP	30,-		Skyscraper	160 x 600 px Desktop ROS TKP	30,-		MPU	300 x 250 px Desktop/Mobile ROS TKP	30,-
	Halfpage Ad	300 x 600 px Desktop/Mobile ROS TKP	50,-		Billboard	970 x 250 px Desktop ROS TKP	50,-		Outstream	16:9 mind. 1.280 x 720 px max. 1.920 x 1.080 px TKP 10-25 sec	50,-
	Newsletter inclusion	<ul style="list-style-type: none"> • 25.000 recipients • on a fortnightly base • Integration options MPU (300 x 250 px) or Content-Teaser ROS TKP	70,- / price 1.750,-								

	Home Page Range Package	<p>The advertising of an extra class: Billboard and Half Page Ad as well as an individual background color let the start page carpediem.life appear in your layout for one week. This allows you to achieve maximum attention for your advertising message. Only fixed placement possible. Mobile gets your message through two consecutive advertising contacts the greatest possible attention.</p>	9.900,-
		<ul style="list-style-type: none"> • Billboard and Half Page Ad / MPU • Inking of the page (background image on request) Runtime: 1 week for fixed placement of advertising according to agreement and coloring Total runtime: 4 weeks	Guaranteed performance values in the RBMH network DACH: <ul style="list-style-type: none"> • 200.000 Ad Impressions within 4 weeks

Social media activities are implemented by the editorial team.

10% surcharge pro filter and frequency capping, further ad tools upon request.

All prices in Euro and do not include statutory taxes and charges. Technical specifications: <https://redbullmediahouse.com/specs>

All information on general terms and conditions and data delivery for the online portal at: <https://redbullmediahouse.com/agb-digital>

CONTENT & SOCIAL MEDIA FORMATS



Advertorial

You supply text and image material, and we design your advertorial in the look and feel of the website. Video integration is also available as an option.
Runtime: 1 month+

Guaranteed performance values DACH:

- 1.000 Ad Impressions via Content Teaser
- 10.000 Social-Media-Impressions

1.450,-
incl. design costs



Native Story

You define the communication message and we present you with an implementation idea. The concept and implementation come from the editorial team. This ensures that your contribution fits in perfectly with the editorial coverage.

Performance values DACH

- 1.000 Ad Impressions via Content Teaser
- 10.000 Social Media Impressions

1.950,-

- SEO optimized article with a target value of 500 page views
- Social media activation

Runtime: 1 month+

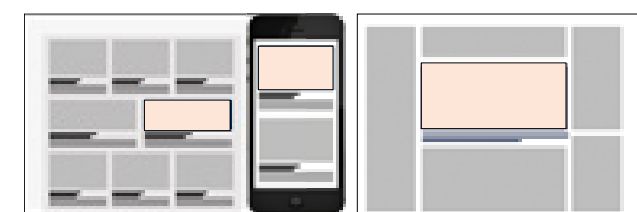

**Video
60 seconds /
1 product**

carpediem.life puts a product prominently in the spotlight in an article including a 60-second video.

In a specially produced short video, the product is shown in its application and the most important details are highlighted.

- Video format for natural cosmetics and related industries
- Product is delivered
- Subtitles/inserts/captions are defined in coordination defined in coordination with the customer

Runtime: 1 month+

Services:

- Placement of the video on the homepage (1 week)
- Activation via social media (Facebook posting) incl. link to the online store in the subtitle/insert/caption
- Layout of the video in a carpe diem Instagram story (incl. swipe-up linking + hashtags)

Average performance values DACH

- 10.000 Social-Media-Impressions

2.450,-

PRIZE GAME

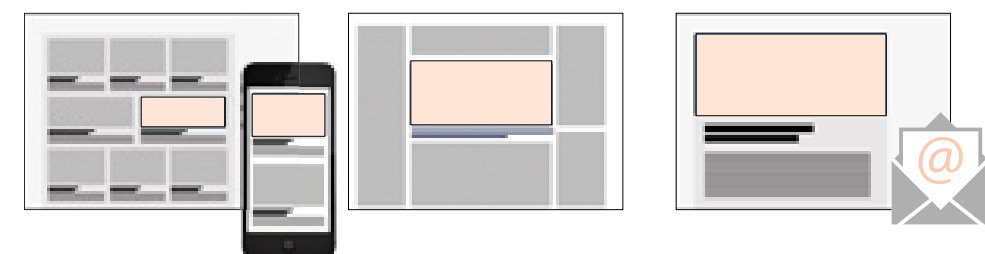

The online competition on carpediem.life

- You choose the prize.
- prepared and placed in the form of an advertorial (product presentation & direct linking)

Runtime: 1 month+

Services:

- Promotion of the article with the content teaser
- Social media activation (Facebook posting)
- 1x integration of the article teaser in the newsletter

1.450,-
incl. design costs



Podcast episode

- Presence in an episode (max. 30 Sec.)
- Advertising placement:
"Zeit für ein gutes Leben": one placement per episode

- Advertising message**
- Recorded as host read (text template from customer)
 - Recorded as commercial by one of our speakers¹
 - delivered as finished commercial²

1.000,-



Podcast episode exclusive

ZEIT FÜR EIN GUTES LEBEN
Exclusive sponsor of the episode
Exclusive presenting partner („This podcast is presented to you by ...“)
up to three placements (Pre-Roll, Mid-Roll & Post-Roll)

- Advertising message**
- Recorded as host read (text template from customer)
 - Recorded as commercial by one of our speakers¹
 - delivered as finished commercial²

1.800,-

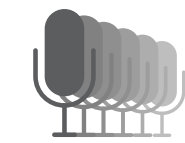

Podcast package exclusive

ZEIT FÜR EIN GUTES LEBEN
Exclusive sponsor of the package (4 episodes)
Exclusive presenting partner („This podcast is presented to you by ...“)
up to three placements (Pre-Roll, Mid-Roll & Post-Roll)

- Advertising message**
- Recorded as host read (text template from customer)
 - Recorded as commercial by one of our speakers¹
 - delivered as finished commercial²

4 episode package

6.600,-

Note: The text templates must be delivered at least 3 weeks before broadcast.

¹ The speaker is not necessarily the host.

² Format: wav; duration: max. 30 sec.

Prices do not include statutory taxes and duties.